

Complex Permittivity of Low Loss Thermoplastic Composites Using a Resonant Cavity Method

H S Ku¹, J A R Ball², E Siores³ and P Chan⁴.

¹ Faculty of Engineering and Surveying, University of Southern Queensland, Australia and PhD Candidate, Swinburne University of Technology, Australia.

² Associate Professor and Head, Electrical, Electronic and Computer Engineering, Faculty of Engineering and Surveying, University of Southern Queensland, Australia.

³ Professor and Executive Director, Industrial Research Institute Swinburne (IRIS), Swinburne University of Technology, Australia.

⁴ Faculty of Engineering and Surveying, University of Southern Queensland, Australia.

SUMMARY: The use of high energy rate joining of fibre-reinforced thermoplastic (FRTP) composites using microwaves has yielded promising preliminary results [1][2][3] and more research is being carried out so that the technology can find its application in manufacturing industries shortly. Methods such as the dielectric probe and waveguide transmission have been successfully used to measure the dielectric constant (ϵ') of low loss thermoplastic composites but they cannot give reliable results when used to measure the dielectric loss (ϵ'') [4][5][6]. This paper describes a convenient laboratory based method designed to obtain ϵ' , ϵ'' and hence loss tangent ($\tan \delta$) for low loss thermoplastic composite materials like glass fibre reinforced (33%) low density polyethylene [LDPE/GF(33%)]. The method is called the resonant cavity method and the schematic diagram of the set up and that of the cavity is depicted in Fig.1 and Fig. 2 respectively..

KEYWORDS: resonant cavity, perturbation, microwaves, Q factor, dielectric constant, dielectric loss and loss tangent.

INTRODUCTION

Since neither the waveguide transmission technique nor the dielectric probe method could measure the dielectric loss of low loss materials satisfactorily [4][5][6], another method called the resonant cavity method was tried [7][8]. This utilises a microwave network analyser to measure the two dielectric properties by a reflection method. The basis for this method was to measure the shift in quality (Q) factor and resonant frequency when the composite, LDPE/GF(33%) was inserted to the initially emptied cavity. The cavity is made from standard waveguide eg. WR340 with short circuit plates screwed to flanges at each end. The Q factor is usually defined as:

$$Q = 2\pi \times (\text{energy stored})/(\text{energy lost per cycle}) \quad (1)$$

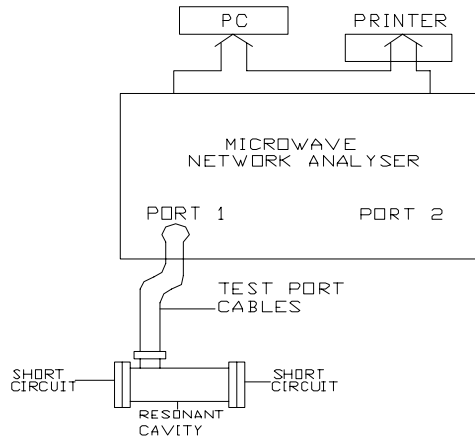

Fig. 1. : Set-up for Cavity Method

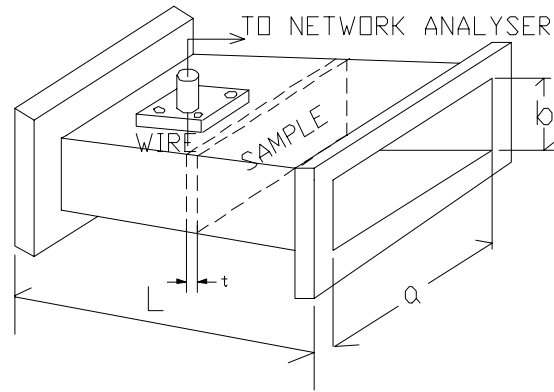

Fig. 2. : Resonant Cavity

Because the Q factor is described in terms of energy storage inside the cavity, with the composite inside the cavity, the energy storage will be perturbed. The application of the perturbation method to cavity resonators is described by Altman [7]. Consider an initially unperturbed, air-filled cavity, which has a resonant frequency ω_o , dielectric constant, ϵ_o and volume V; the fields inside the cavity are represented by electric field E_o and magnetic field H_o . In the presence of a small sample of material such as LDPE/GF(33%) with a volume of ΔV and a dielectric constant, ϵ' , the resonant frequency in the cavity is shifted to ω_s [7][9]. The perturbation of the cavity results in the shift in the resonant frequency and also a change in the Q factor. The following equations may be derived using the perturbation method [7][10]:

$$\left(\frac{\omega_s - \omega_o}{\omega_o} \right) = \frac{-\epsilon_o(\epsilon' - 1) \left(\int E_o^* \cdot E_s dv \right)}{4U_{total}} \quad (2)$$

$$\frac{1}{Q_s} - \frac{1}{Q_o} = \frac{\epsilon_o \epsilon'' \left(\int E_o^* \cdot E_s dv \right)}{2U_{total}} \quad (3)$$

where ω_s : resonant frequency with sample;

ω_o : resonant frequency with empty cavity;

Q_s : the Q factor for cavity with sample;

Q_o : the Q factor for empty cavity;

ϵ_o : the permittivity of free space;

ϵ' : the real part of complex relative permittivity for empty cavity;

ϵ'' : the imaginary part of complex relative permittivity for empty cavity;

E_o : the electric field in an empty cavity;

E_s : the electric field in a cavity with sample;

U_{total} : total average stored energy in the cavity.

Suppose that the sample takes the form of a thin slab of thickness t placed upright in the centre of the cavity and extending across the entire waveguide cross-section, as shown in Fig. 2. In the empty cavity the only component of electric field will be in the vertical direction. The introduction of a thin sample as shown will cause very little alteration, since tangential electric field is a continuous across a material interface. Using this assumption, Eqn 2 and

Eqn 3 may be evaluated for the configuration shown. If the sample is located at an electric field maximum then after manipulation [11], Eqn 2 becomes

$$\left(\frac{\omega_s - \omega_o}{\omega_o} \right) \cong \frac{-(\epsilon' - 1)t}{L} \quad (4) \text{ and Eqn 3}$$

becomes

$$\frac{1}{Q_s} - \frac{1}{Q_o} \cong \epsilon'' \left[\frac{2t}{L} \right] \quad (5)$$

where t : the thickness of the sample material in cm;

L: the length of the cavity in cm.

With the aid of Eqn 4 and Eqn 5, the complex relative permittivity of the sample and subsequently the loss tangent can be evaluated.

THE CAVITY LENGTH

In order to make the cavity containing a sample resonant at a particular frequency, the empty cavity should be made resonant at a higher frequency. Taking an operating frequency of 2.45 GHz as an example, the empty cavity has to be made resonant at approximately 2.65 (f_o) GHz when the waveguide selected is WR340. At the fundamental resonance the cavity length is equal to half of the waveguide wavelength. Using [12]

$$\left(\frac{1}{2L} \right)^2 + \left(\frac{1}{2a} \right)^2 = \left(\frac{1}{\lambda_o} \right)^2 \quad (6)$$

where L is the length of the cavity in cm;

a is the broader side of the waveguide in cm;

λ_o is the wavelength of electromagnetic field in free space in cm.

$$\lambda_o = \text{velocity of light} / f_o = \frac{30 \times 10^9}{2.65 \times 10^9} = 11.32 \text{ cm.}$$

a = 2.54 x 3.4 cm = 8.836 cm and substituting both values of λ_o and a into Eqn 6 gives

$$\left(\frac{1}{2L} \right)^2 = \left(\frac{2.65}{30} \right)^2 - \left(\frac{1}{2 \times 8.836} \right)^2 \text{ or } 2L = 14.99 \text{ cm or } L = 7.5 \text{ cm.}$$

Using Eqn 4, and assuming the values of t = 0.4, $\epsilon' = 2.6$ and $f_o = 2.65$ GHz

Eqn 4 becomes $\frac{f_s - f_o}{f_o} \approx -(2.6 - 1) \times \frac{0.4}{7.5}$ and f_s becomes = 2.44 GHz which is not far from

the operating frequency and the initial estimate of $f_o = 2.65$ is close enough. Similarly, other targeted frequencies are tabled in Table 1.

CALIBRATION OF NETWORK ANALYSER

The network analyser has to be 1-port calibrated with open, short and broadband load standards. After making the correct calibration and before removing the broadband load, a point 'P' should be found in the centre of the Smith Chart as depicted in Fig. 3.

Table 1. Relationship Between Initial and Targeted Frequencies.

Targeted Frequency (f) With Sample (GHz)	Initial Frequency (f ₀) Without Sample (GHz)	Waveguide Type	Cavity Length (cm)
2.45	2.65	WR340	7.5
3.5	3.84	WR229	5.13
6	6.4	WR159	8.6
9	9.85	WR90	6.1

The probe coupled cavity is then connected to the network analyser. Consider a WR229 LDPE/GF(33%) filled cavity, both ends of it are short-circuit by two short-circuit plates; the plates are joined to the cavity with screws tightened to the same amount of torque force. The sample is made stand upright in the middle of the cavity by placing it between two slabs of polystyrene foam that has a low value of permittivity, approximately equal to unity. When the cavity is resonant with the sample [LDPE/GF(33%)] at 24 °C, select and view the Smith Chart display option of the network analyser and it will be found that the loop of reflection coefficient ‘C’ is repeatedly traced out as depicted in Fig. 4. The cavity is said to be undercoupled because the loop did not enclose the centre of the Smith Chart. Select and view the magnitude and phase and options of the equipment respectively and their views are separately shown in Fig. 5 and 6. Fig. 7 and 8 are the simplified versions of the above two views respectively. After this, the resonant frequency of the cavity without sample was then measured. The two slabs of polystyrene foam were also in place when the cavity was resonant with no sample. This time the reflection coefficient loop encloses the centre of the Smith’s chart and the cavity is said to be overcoupled. The Q factors of the cavity with and without sample can then be calculated from one of the four methods available [7][11]. The imaginary part of the permittivity of the sample [LDPE/GF(33%)] can be found by the shift of ‘Q’ factor.

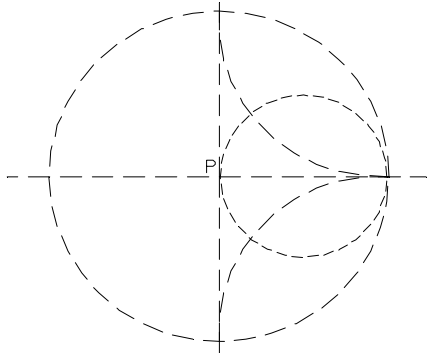

Fig. 3. : Smith's Chart After Calibration

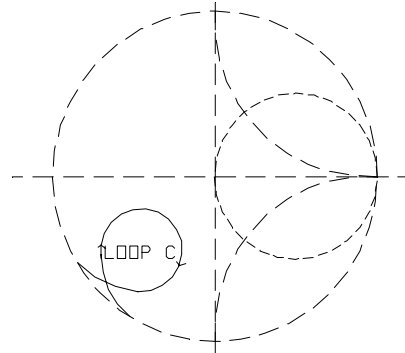

Fig. 4. : Smith's Chart of LDPE/GF(33%) Filled WR229 Cavity During Resonant

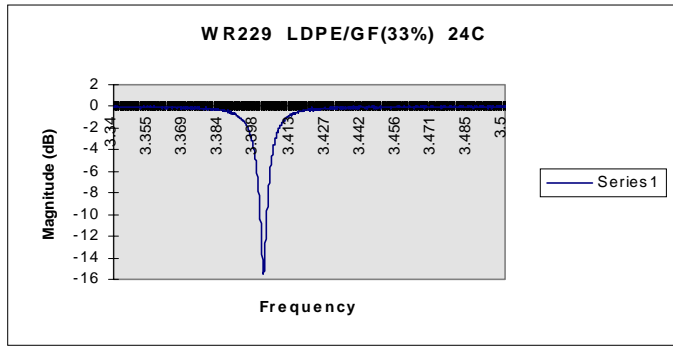

Fig. 5.: Magnitude View of LDPE/GF(33%) Filled WR229 Cavity

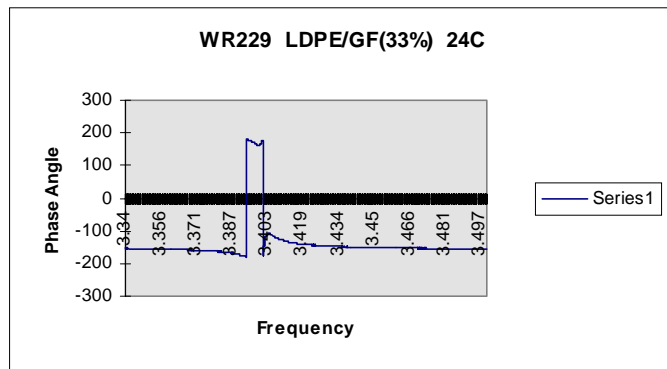

Fig. 6.: Phase View of LDPE/GF(33%) Filled WR229 Cavity

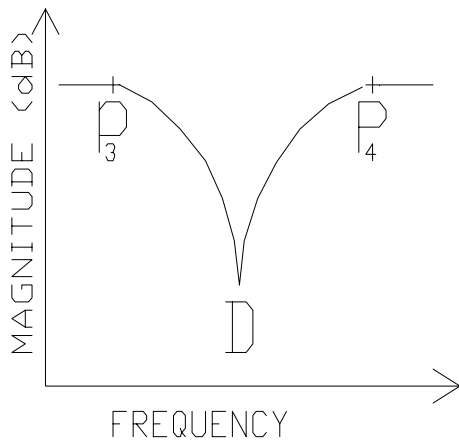

Fig. 7. : Simplified Magnitude View

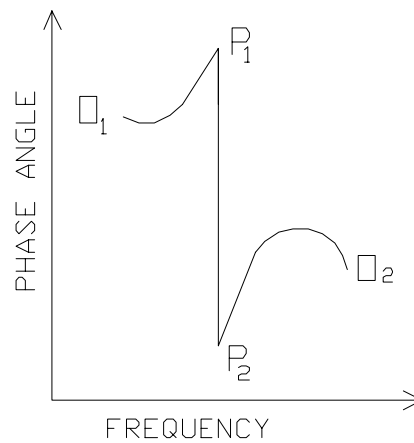

Fig. 8.: Simplified Phase View

FORMULAE FOR CALCULATING Q FACTOR

The four methods are phase turning points, magnitude only, $\pm 90^\circ$ method and phase slope method. The phase turning point method is applicable to undercoupled situations only and the $\pm 90^\circ$ method to overcoupled situations only; while the other two methods can be used for both undercoupled and overcoupled cases but the equations used are not totally the same.

Phase Turning Points

Let us consider the phase turning point method first; because of the limitation of the network analyser to display something less than -180° , or more than 180° , the phase curve tends to return to 180° if it crosses the -180° barrier and vice-versa. This is called the 'wrap around' effect. The phase trace in Fig. 8 has therefore to be shifted to the one shown in Fig. 9, the phase trace is now from O_1 , P_2 and O_2 ; the resonant frequency, f_o can be found from Fig. 5 and f_a and f_b are the frequencies of the two turning points employed in the calculation of Q factor. When the WR229 cavity was filled with sample, the resonant frequency, f_o at 24°C was found to be 3.40135 GHz and the frequencies and phases of the minimum point and maximum point were respectively 3.3992 (f_a) GHz and $(161.60^\circ - 360^\circ) = -198.40^\circ$ (θ_1), and 3.4035 (f_b) GHz and -108.45° (θ_2). If the phase difference between the two extreme points was $2\phi_m$, then $2\phi_m = (\theta_2 - \theta_1) = -108.45^\circ - (-198.40^\circ) = 89.95^\circ$ or $\phi_m = 44.975^\circ$. Using [11]

$$\left(\frac{f_b - f_a}{f_o} \right) = \left(\frac{1}{Q} \right) \text{Cos}\phi_m \quad (7)$$

where f_a , f_b and f_o are the frequencies of the extreme points and the resonant point respectively. Substituting the values of f_a , f_b , f_o and $\text{Cos}\phi_m$ into Eqn 3 gives

$$Q_s = 0.7074x \frac{3.40135}{3.4035 - 3.3992} = 0.7074x \frac{3.40135}{0.0043} = 559.57,$$

where Q_s is the Q factor with sample [9].

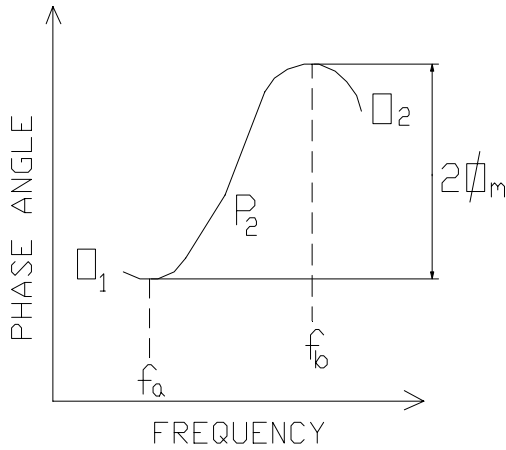

Fig. 9. : Shifted Phase View

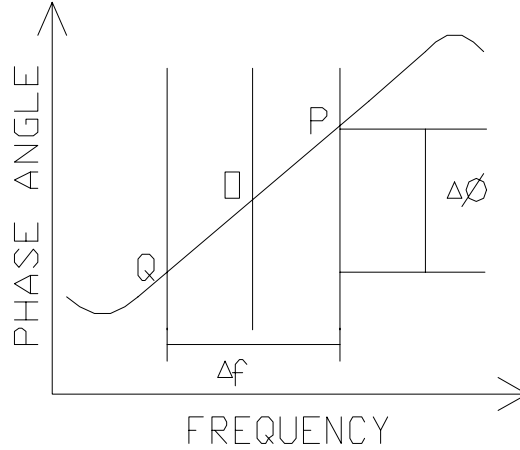

Fig. 10.: Phase Angle Against Frequency

Magnitude Only Method

The process was repeated with no sample in the cavity and at the same temperature. In this case, the cavity was overcoupled. The magnitude only method was therefore used to calculate the Q factor with no sample. Referring to Fig. 7, the magnitudes and frequencies of P3 and P4 are -1.92889dB ($|\rho_a| = 0.80086$) and 3.8272 GHz (f_a), and -1.91638dB ($|\rho_b| = 0.8020$) and 3.8362 GHz (f_b) respectively. The average reflection coefficient at these points was therefore $|\rho| = 0.801435$. The magnitude and frequency of the dip, D, were -3.900dB and

3.8319 GHz (f_o) respectively and the minimum reflection coefficient, $|\rho_{\min}| = 10^{\frac{-3.9}{20}} = 0.638263$.

Using [11]

$$Q_o = \frac{f_o}{f_b - f_a} \frac{2}{(1 - |\rho_{\min}|)} \sqrt{\frac{|\rho|^2 - |\rho_{\min}|^2}{1 - |\rho|^2}} \quad (8)$$

where Q_o is the Q factor with no sample.

The Q factor without sample

$$Q_o = \frac{3.8319}{0.009} \times \frac{2}{1 - (0.638263)} \times \sqrt{\frac{(0.801435)^2 - (0.638263)^2}{1 - (0.801435)^2}} = 1907.68$$

Again using Eqn 5 and substituting the values of the variables into the equation,

$$\frac{1}{560} - \frac{1}{1908} = \frac{2\varepsilon'' \times 0.4}{5.13}. \text{ This gives } \varepsilon'' = 0.0809.$$

Modify Eqn 4 so that it becomes

$$\frac{f_s - f_o}{f_o} \cong \frac{-(\varepsilon' - 1)t}{L} \quad (9)$$

Substitute the values of $f_s = 3.40135$, the shifted frequency and $f_o = 3.8319$, original frequency into Eqn 9 and it was found that $\varepsilon' = 2.44$.

If the cavity were undercoupled a slightly different equation should be used [8].

$$Q_o = \frac{f_o}{f_b - f_a} = \frac{2}{(1 + |\rho_{\min}|)} \sqrt{\frac{|\rho|^2 - |\rho_{\min}|^2}{1 - |\rho|^2}} \quad (10)$$

Phase Slope Method

The two remaining methods are the phase slope method and the $\pm 90^\circ$ method. Let us consider the phase slope method first and take the data of LDPE/GF(33%)-filled cavity (WR229) at 24°C. The point O in Fig. 10 was the resonant frequency; its frequency and phase angle were 3.4013 GHz and -153.219° respectively. In order to calculate the rate of change of phase angle with respect to frequency, it was necessary to locate some points near the resonant frequency. Points P and Q which were adjacent to the resonant frequency point, O, were identified and shown in Fig. 10. The coordinates of points P and Q were 3.4012 GHz and -158.898° , and 3.4014 GHz and -147.859° respectively. Therefore, $\Delta\phi = 11.309^\circ$ and $\Delta f = 0.0002$ GHz and $d\phi/df = 11.039/0.0002$ degrees/ GHz = $11.039/0.0002 \times \pi/180$ rad/GHz = 963.334 rad/GHz. It should be noted that the slope was positive and the cavity was undercoupled. The magnitude at the resonant frequency was found to be -15.4224 dB and $|\rho_{\min}|$ was therefore = 0.169387.

Using [11]

$$Q_s = f_o \left(\frac{d\phi}{df} \Big|_{f_o} \right) \frac{|\rho_{\min}|}{(1-|\rho_{\min}|^2)} \quad (11)$$

$$Q_s = 3.4013 \times 963.334 \times \frac{0.169387}{1-(0.169387)^2} = 571.406,$$

which was very close to that (559.57) obtained by the phase turning point method.

If the cavity were overcoupled, the slope, $\frac{d\phi}{df}$, will be negative and Eqn11 should have its sign changed and becomes [11]

$$Q_s = f_o \left(-\frac{d\phi}{df} \Big|_{f_o} \right) \frac{|\rho_{\min}|}{(1-|\rho_{\min}|^2)} \quad (12)$$

± 90° Method

Finally, we are going to show how the Q factor of an overcoupled cavity can be calculated by ± 90° method. This time consider the data for an empty WR229 cavity at 24°C. First, it is necessary to locate the two frequencies at which the reflection coefficient phase is ± 90° relative to its value at the cavity resonant frequency. The resonant frequency was 3.8319 and the frequencies at phase angles of +90 and -90 were 3.8276 GHz and 3.8365 GHz respectively and $|\rho_{\min}| = 0.638263$.

Again, using [11]

$$Q_o = \frac{f_o}{\Delta f} \frac{2\sqrt{|\rho_{\min}|}}{(1-|\rho_{\min}|)} \quad (13)$$

$$Q_s = \frac{3.8319}{0.0089} \frac{2\sqrt{0.638263}}{(1-0.638263)} = 1901.78,$$

which was again very close to that (1907.68) procured by the magnitude method.

The above measurements have been carried out with the sample stood upright in the middle of the cavity and it was shown that the four methods could produce reliable values of Q factors which could then be used to evaluate values of ϵ' and ϵ'' . The values of dielectric loss, dielectric constant and Q factors for WR340, WR229 are tabulated in Tables 2 - 3.

RESULTS

With both WR340 cavity and WR229 cavity, the values of the dielectric loss of the two sets of data are quite close to each other; in both cases, the values increase with the rise in temperature. The increase is insignificant but the trend is there. With WR340 ie at a lower frequency, the values of the dielectric loss range from 0.00606 at room temperature to 0.0071 at 80°C; while those with WR229 ie at a higher frequency range from 0.00809 at 24°C to 0.00983 at 80°C. The values are, however, three to five times higher than the simulated value of 0.0018 at 3GHz and 25°C [5]. It can be argued that the experimental results are more reliable and accurate than the simulated one because they have been measured separately and independently and in different frequency ranges.

Table 2. Values of ϵ' and ϵ'' for WR340 with Sample [LDPE/GF(33%)] Standing Upright.

WR340 Temp	Dielectric Loss	Dielectric Constant	Q ₀	Q _s
24°C	0.00606	2.249	4795	1169
42°C	0.00678	2.238	4873	1077
60°C	0.00684	2.230	5005	1076
80°C	0.00711	2.228	4810	1035

Table 3. Values of ϵ' and ϵ'' for WR229 with Sample [LDPE/GF(33%)] Standing Upright.

WR229 Temp.	Dielectric Loss	Dielectric Constant	Q ₀	Q _s
24°C	0.00809	2.44	1908	560
40°C	0.00816	2.373	1834	550
60°C	0.00909	2.370	1896	514
70°C	0.00944	2.368	1923	502
80°C	0.00964	2.365	2017	500
90°C	0.00983	2.363	2017	497

Now looking at the values of dielectric constant of the material under test; it is found that both the results of WR340 cavity, decreasing from 2.249 at 24°C to 2.228 at 80°C, and the results of WR229 cavity, ranging down from 2.44 at 24°C, to 2.363 at 90°C, are lower than the measured data of 2.6 [4] [5] [6] and simulated data of 2.755 [5] respectively. The value of 2.6 has been obtained from two different measurement techniques, waveguide transmission method and dielectric probe technique [5] and is therefore regarded as accurate and reliable. The values of dielectric constant from Table 2 and Table 3, however, have the same trend as those measured from the other two techniques [5] i.e. the values decrease with increasing temperature.

CONCLUSION

It is believed that the values of dielectric loss of LDPE/GF(33%) in Table 2 and Table 3 are correct but further experiments using WR159 and WR90 cavities will be carried out shortly with the sample in different orientation to test the authenticity of results in the two cavities. At the same time, the value of the dielectric constant of LDPE/GF(33%) can also be confirmed.

REFERENCES

1. H.S.Ku, J.A.R. Ball and E. Siores, Weldability and Heat Affected Zone (HAZ) Evaluation for High Energy Rate Joining of Thermoplastic Composites Using Microwaves, Proceedings of the Eleventh International Conference on Composite Materials, Gold Coast, Australia, July, 1997, Vol. VI, pp.55-64.
2. H.S.Ku, J.A.R. Ball and E. Siores, Welding of Thermoplastic Composites Using Microwave Energy, Proceedings of CIRP International Symposium, Hong Kong, August, 1997, pp.612-9.
3. H.S.Ku, J.A.R. Ball and E. Siores, Microwave Facilities for Welding Thermoplastic Composites, and Preliminary Results, Journal For Microwave Power and Electromagnetic Energy, 1999 (submitted for publication).
4. H.S.Ku, J.A.R. Ball, E. Siores, B. Horsfield, Microwave Processing and

Permittivity Measurement of Thermoplastic Composites at Elevated Temperature, Journal of Materials Processing Technology, 1999 (accepted for publication).

5. H.S.Ku, J.A.R. Ball, E. Siores, B. Horsfield, Permittivity Measurement of Thermoplastic Composites at Elevated Temperature, Journal For Microwave Power and Electromagnetic Energy, 1999 (submitted for publication).
6. H.S.Ku, J.A.R. Ball, E. Siores, B. Horsfield, An Important Step in Microwave Processing of Materials : Permittivity Measurements of Thermoplastic Composites at Elevated Temperatures, Proceedings of Pacific Conference on Manufacturing 98, August, 1998, pp.68 - 73.
7. J.L., Altman, and D.V. Nostrand, Perturbation Formulas For Cavities and Waveguides, Microwave Circuits, C. Inc., 1964, pp. 409-16.
8. Garner, H.R., et al, Measurement of Permittivity at Elevated Temperatures Using Cavity Perturbation and CO₂ Laser Irradiation, Rev. Sci. Instrum. 61(7), July, 1990, pp. 1832-4.
9. P. Chan, B Eng Dissertation, Dielectric Properties of Composite Plastics at Microwave Frequencies, 1998, pp.2, 3, 7, 10-12.
- 10.. R. Meredith, Engineers' Handbook of Industrial Microwave Heating, Institution of Electrical Engineers, London, United Kingdom, 1998.
11. J.A.R., Ball, Formulae for Q factor calculations, unpublished, 1998.
12. E.V.D. Glazier, and H.R.L. Lamont, 1958, Transmission and Propagation, The Services' Textbook of Radio, Volume 5, London, Her Majesty's Stationery Office, 1958, pp. 161-2.